



**WAREWASHING/HANDLING**

**SERVING THE FOOD INDUSTRY SINCE 1951**

**POT SINKS -  
THREE TUB SINK WITH TWO DRAIN BOARDS AND CORNER SINK**



Designed with durability in mind, this three tub sink is the perfect appliance for your washing tasks big and small and an excellent addition for all your commercial kitchen needs!



Authorized Dealer



**LIMITED  
WARRANTY**

# WAREWASHING/HANDLING

## POT SINK - 18" x 18" x 14" THREE TUB SINK



### Features:

- 18-gauge stainless steel sink with 2 drainboards
- Shipped with 16-gauge, galvanized legs removed
- Comes with socket and plastic bullet feet
- Center Drain size: 3.5" drain basket included
- Conforms to CSA Standards

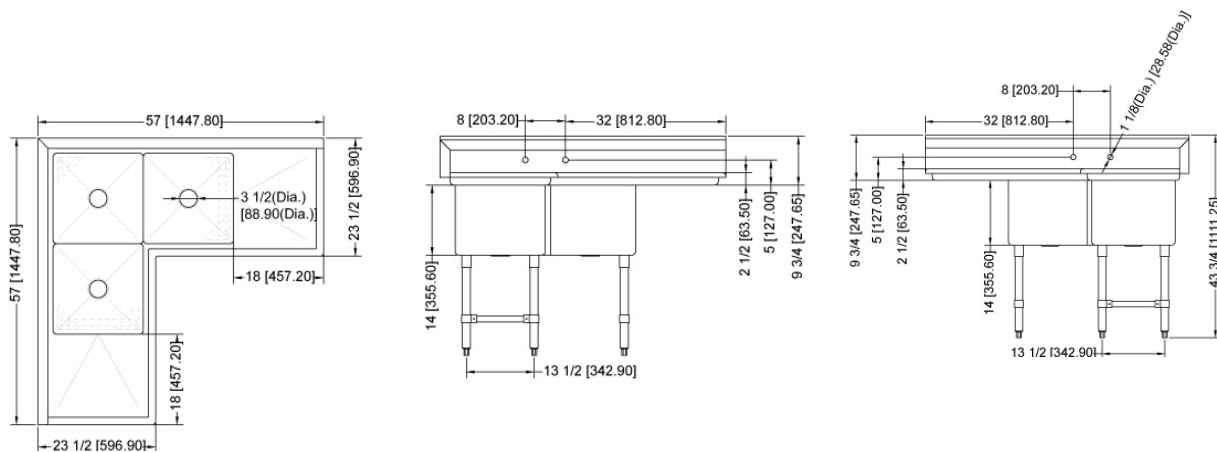

### TECHNICAL SPECIFICATION

ITEM NUMBER	43073
DESCRIPTION	18" X 18" X 14" THREE TUB SINK WITH TWO DRAIN BOARDS AND CORNER SINK
NET WEIGHT	79 lbs.
GROSS WEIGHT	99 lbs.
DIMENSIONS OF SINK	18"x18"x14" / 457.2 mm x 457.2mm x 355.6 mm
OVERALL DIMENSIONS	57" x 57" x 44"/1447.8 x 1447.8 x 111.6 mm
GROSS DIMENSIONS	59 "x 24" x 29 " / 1498.6 x 609.6 x 228.6 mm

### OMCAN INC.

Telephone: 1-800-465-0234  
 Fax: (905) 607-0234  
 Email: sales@omcan.com  
 Website: www.omcan.com



Follow us to keep up to date with the latest news and offers



2015.E.O.E